



1



2

Energetic Wheel

- So far, we've represented energetics as a cycle, circle, or wheel
- We've also pointed out that these cycles are found everywhere
- But in reality, the wheel of life isn't a circle, it's a spiral

3



4

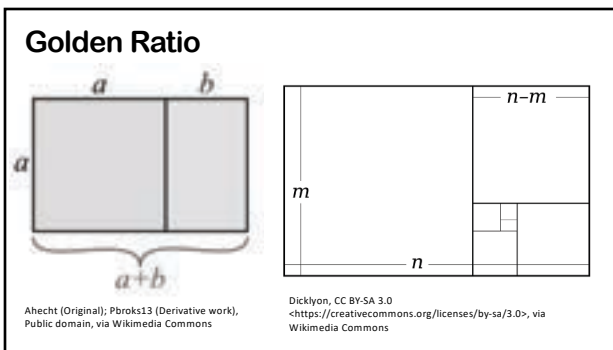

5

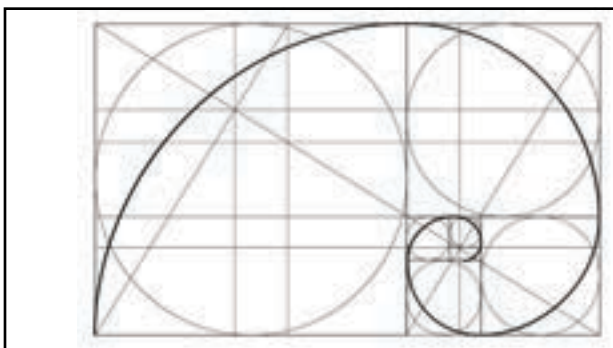

6

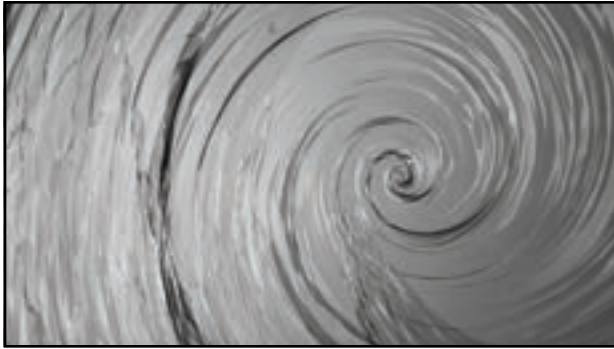

7

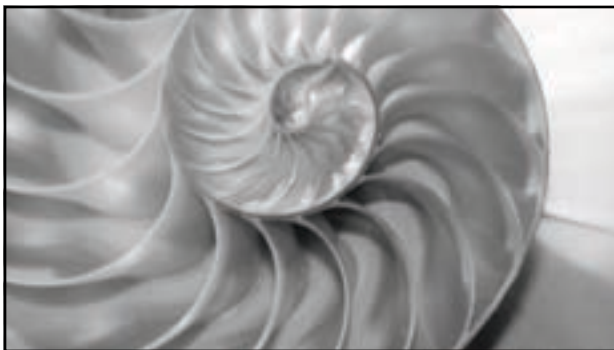

8

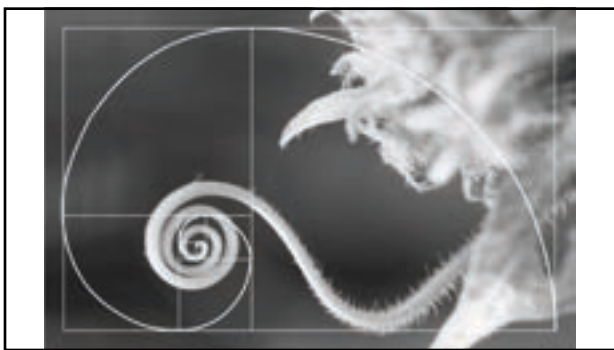

9



10



11

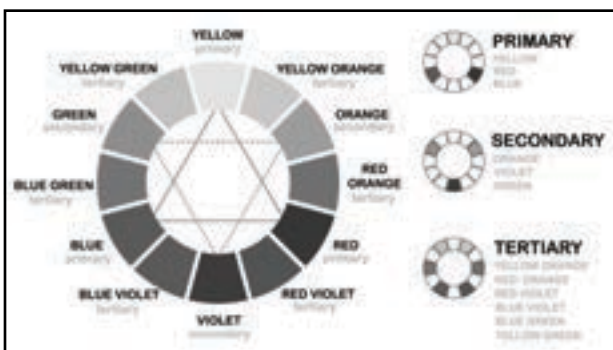

12

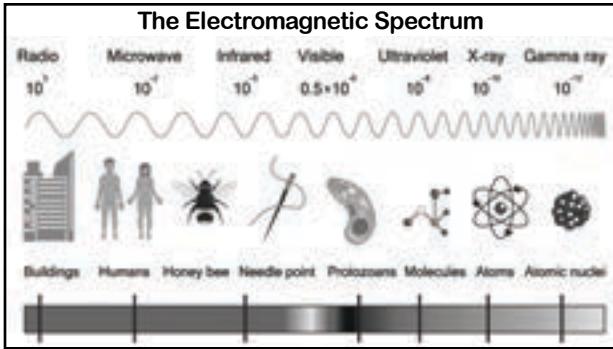

13

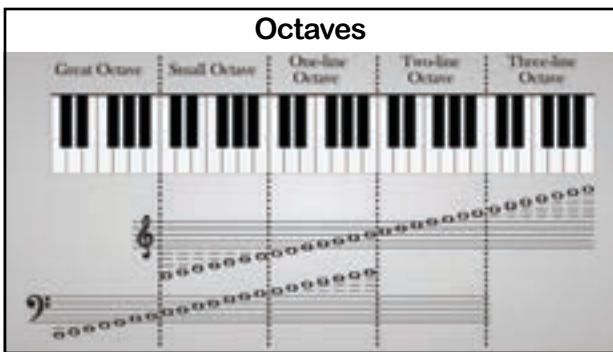

14

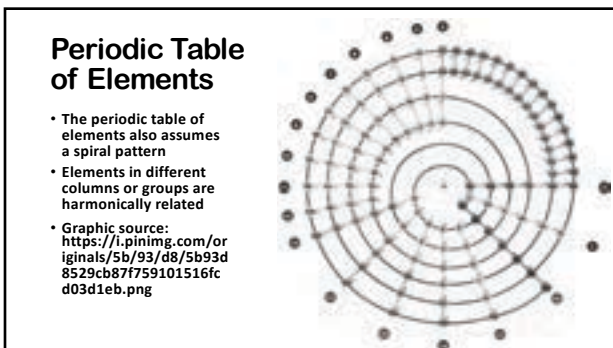

15

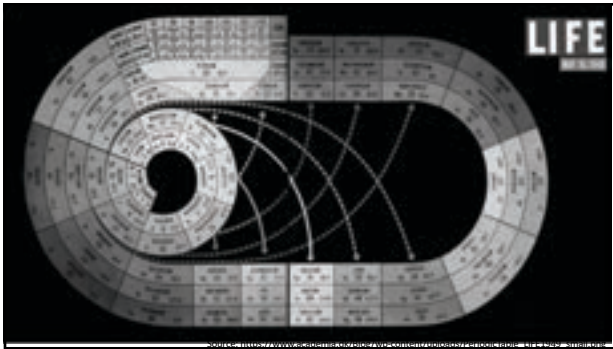

16



17

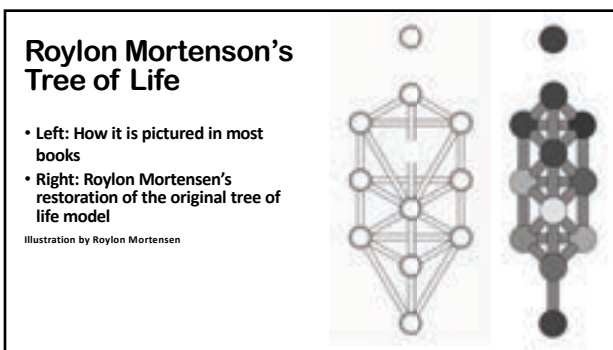

18

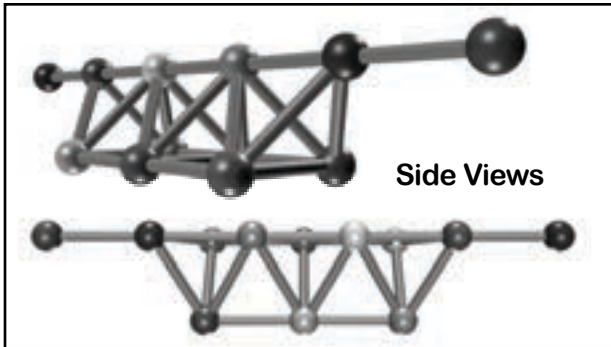

19

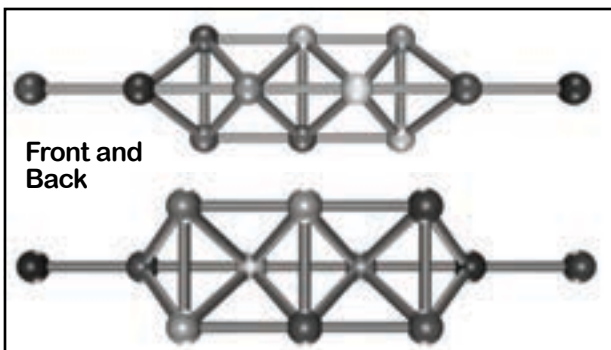

20

Tree of Life Basics

- 3 pillars
- 3 worlds (tetrahedrons)
- 2 pyramids
- 12 spheres
- 22 pathways
 - 3 horizontal pathways
 - 7 vertical pathways
 - 12 diagonal pathways

21

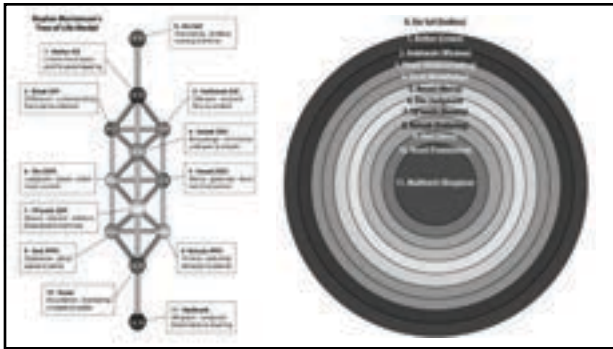

22

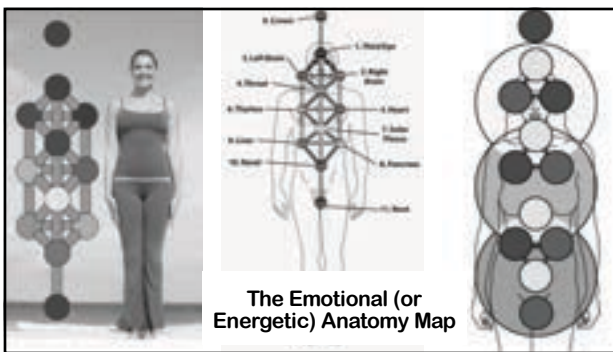

23

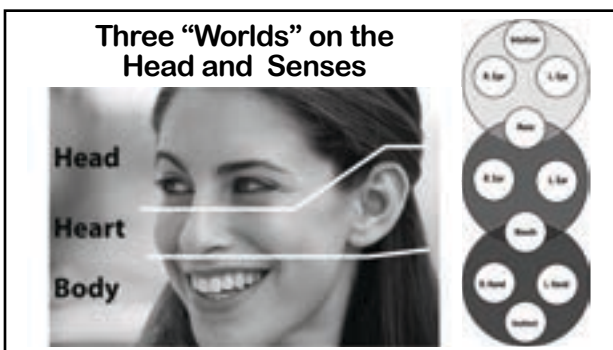

24

Iridology and Eye Movements

- **Jewel**
 - Mental type
 - Visual learner
- **Flower**
 - Emotional type
 - Auditory learner
- **Stream**
 - Physical type
 - Kinesthetic learner

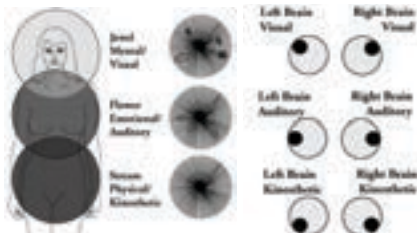

25



Energetics
and
Personality

26

Aspects of Constitution

- **Physical**
 - Body type
 - Facial features
 - Strengths and weaknesses in body systems
 - Disease tendencies
- **Personality**
 - Primarily learning mode
 - Temperament
 - Modes of self-expression



27

Constitutional Typing Systems

- Western four element
- Chinese five element
- Ayurvedic tridosha
- Iridology (Physical and Rayid)
- Glandular body typing
- Brain Typing (E/I, S/N), T/F, J/P)
- Enneagram



28

Properly Using Constitutional Typing

- The purpose of constitutional typing is not to put people in boxes
- Everyone is a unique blend of the basic personality characteristics
- Use it to understand yourself better
- Use it typing to help you understand people, not judge them
- It can help you communicate and work with other people better
- It can also be used to screen who is best suited for various types of tasks or projects



29

Four Element Personality Types

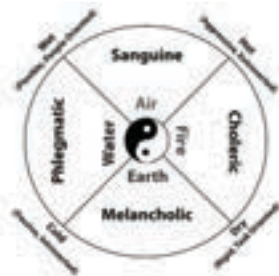

30

4-Element Personality Typing Systems

System	Air	Water	Fire	Earth
Traditional	Sanguine	Phlegmatic	Choleric	Melancholic
Animal Types	Otter	Golden Retriever	Lion	Beaver
Relationship Types (KWMML)	Magician	Lover	Warrior	King/Queen
DISC	Influencing	Compliant	Dominant	Steady
Rayid	Shaker or Flower Extroverted	Flower or Shaker, Introverted	Jewel or Stream, Extroverted	Stream or Jewel, Introverted
Basic Characteristics	Outgoing, friendly, networker	Caring, loyal, empathetic, passive	Dominant, assertive, outgoing	Steady, dependable, reserved

31

Fire (Choleric) Type



- Warriors: Logical, organized, out-going, logical and action oriented
- Lions: Assertive, aggressive, dominant
- Dominant: Ego-centric, driving, ambitious, pioneering, strong-willed, forceful, determined, aggressive, competitive, decisive
- Natural born leaders, high achievers, focused on "getting the job done"
- Good in positions of management or where decisiveness and action is required

32

Choleric Personalities



- Strengths
 - Capable to get things done and done right
 - Make great leaders, generals, CEOs
- Weaknesses
 - Can be overly critical and insensitive
 - Need to learn to listen and take feedback
 - Get bored with repetitive tasks
 - May have difficulty taking direction from others

33

Sanguine (Air) Type



- **Magicians:** Outgoing, spontaneous, creative, action-oriented, performers, adventurous, fun
- **Otters:** wide social circles, like to have fun, entertaining, "life of the party" people
- **Influencers:** Inspiring, magnetic, political, enthusiasm, demonstrative, persuasive, warm, optimistic, sociable
- **Naturally social and easy-going with people**
- **Good in any position that requires interfacing with others, good "master of ceremonies" or entertainer**

34

Sanguine Personalities



- **Strengths**
 - Make excellent adventurers, world travelers, entertainers, teachers and salespeople
 - Good for tasks that require interfacing with others
- **Weaknesses**
 - Can be disorganized, flighty and undependable
 - Not good with details or follow-through, easily side-tracked

35

Phlegmatic Type



- **Lovers:** Creative, spontaneous, shy, passive, nurturing, artistic, kind
- **Golden Retrievers:** Loyal, friendly, caring, compassionate, good listeners, place high value on caring for people
- **Steadiness:** Resistant to change, passive, patient, possessive, predictable, consistent, deliberate, stable
- **Make excellent health care workers, counselors, teachers, care-givers**

36

Phlegmatic Personalities



- **Strengths**
 - Can tolerate large amounts of abuse in relationships and remain loyal
 - Great care-givers, caring and responsive to other people's needs
- **Weaknesses**
 - Have difficulty standing up for themselves
 - Sometimes don't say what should be said
 - May tolerate too much abuse

37

Melancholic (Earth) Type



- **Kings and Queens:** Logical, organized, nurturing, wise
- **Beavers:** Organized, efficient, "detail-oriented," "get the job done" people, can also be artistic
- **Compliant:** Worrisome, careful, dependent, cautious, conventional, exacting, neat, diplomatic, accurate, tactful
- **Make good computer programmers, accountants, managers**

38

Melancholic Personalities



- **Strengths**
 - Good at detailed work
 - Can work with minimal supervision
 - Good at tasks that require precision: engineering, computer programming, accounting
- **Weaknesses**
 - Can be overly sensitive and have trouble speaking up for themselves
 - Need to learn to be more flexible
 - May struggle with perfectionism, trying too hard to get everything right

39

Quotes from Ralph Waldo Emerson's Essay on Compensation

"...in the animal kingdom the physiologist has observed that no creatures are favorites, but a certain compensation balances every gift and every defect. The good are befriended even by weakness and defect."
"Every man in his lifetime needs to thank his faults. As no man thoroughly understands a truth until he has contended against it, so no man has a thorough acquaintance with the hindrances or talents of men, until he has suffered from the one, and seen the triumph of the other over his own want of the same."
"Our strength grows out of our weakness."
"Every thing has two sides, a good and an evil. Every advantage has its tax. I learn to be content."

40

Manifest versus Unmanifest Reality

- Our inner nature will always be the reverse of our projected "outer" nature
- This means that we will always have both sides of any duality within us
- One is projected on the surface, the other is held within
- Thus, each of us embodies a various polarities within us



41



42



43



44



45



46

A Model of Healing

- Disease is created by the imbalance between a person's constitution and the stresses placed on them
- The symptoms of disease are coping mechanisms trying to maintain balance
- The remedy is whatever restores balance, eliminating the need for the coping mechanisms

47

Every healing plant, mineral or animal is the embodiment of a conflict in the environment which has been reconciled. The similar remedy "teaches" the organism how to handle what it is resisting...

— Matthew Wood
Seven Herbs, Plants as Teachers

48

Healing and Wholeness



- The idea is that all illness is caused by a lack of wholeness
- There is some sort of inner or outer conflict
- The conflict may involve being unable to adapt to one's environment or situation
- Or it may be an internal crisis one can't resolve
- Reconciliation of this conflict restores the person to wholeness (health)

49

Plant Gestures (Signatures)

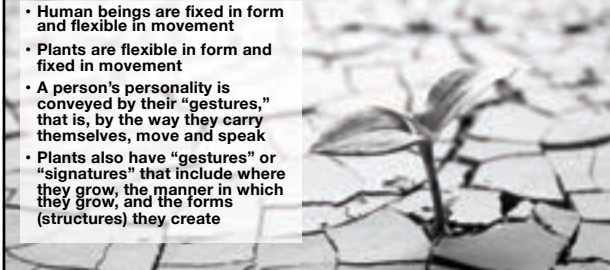

- Human beings are fixed in form and flexible in movement
- Plants are flexible in form and fixed in movement
- A person's personality is conveyed by their "gestures," that is, by the way they carry themselves, move and speak
- Plants also have "gestures" or "signatures" that include where they grow, the manner in which they grow, and the forms (structures) they create

50



Some Basic Plant Signatures

51

Yang (Fire) and Yin (Water)

Yang (Fire) Qualities

- Rigid structures
- Dry, compact structures
- Bolder, fiery colors
- Prickly, thorny nature
- Rapid growth
- More rapid seasonal decline

Yin (Water) Qualities

- Flexible structures
- Juicy, swollen structures
- Softer, pastel colors
- Soft, smooth nature
- Slower growth
- Longer seasonal duration

52

Lilies (Yin)



53

Sunflower (Yang)



54

Four Elements



- **Water**
 - Leafy, especially juicy leaves
 - Grows in watery environment
 - Prefers shade, cool, moist environment
- **Fire**
 - Plentiful, colorful fruits
 - Brightly colored, showy flowers
 - Prefers sunlight, rapid growth pattern
- **Earth**
 - Deep roots, firmly rooted
 - Hard, woody structures
 - Slow growing, flowers inconspicuous
- **Air**
 - Flowery, floral aromatic
 - Lacy structures, spacy, open to the air
 - Ballooned or enclosed structures

55

Water - Fire

Purslane



Mustard



56

Air - Earth

Oak



Caraway



57



58

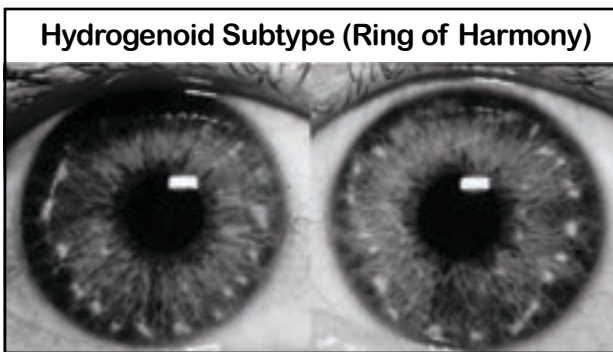

59

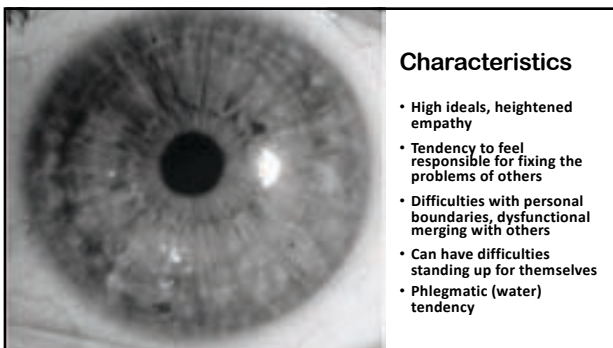

60

Ring of Harmony Life Lessons

- I should serve from strength, not from weakness
- It's OK for other people to have problems, I don't have to fix their problems for them
- I'm responsible for my life, other people need to be responsible for theirs
- I can be empathetic, but I shouldn't be overly sympathetic
- I can offer support, but people need to do their part



61

- For the "wounded warrior and the wounded healer" – Mathew Wood
- Helps people with poor personal boundaries, who feel overly responsible for the welfare of others
- Tendency to be a "rescuer" and save other people from their own choices and problems
- Helps a person create strong personal boundaries, a sense of what is, and is not, their responsibility
- "People need to solve their own problems or they won't learn their life lessons"



White Yarrow

62



- Overly sympathetic who become emotional "sponges"
- Highly influenced by other people's negative emotions
- Often can't tell the difference between their own emotions and the emotions of others
- May become ill from absorbing negative energy from others
- Helps create clear emotional boundaries and a recognition of what is, and is not, my "stuff"
- "Empathy is good, when I don't take on the emotions of others"

Pink Yarrow

63



64

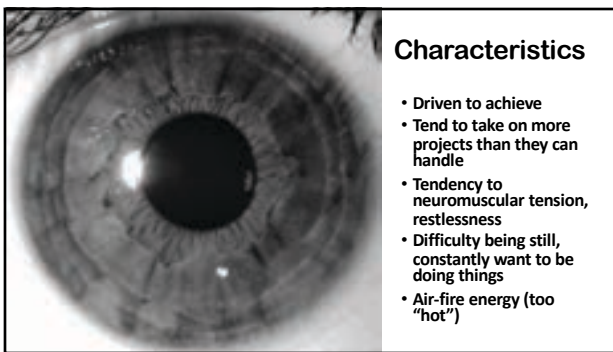

65

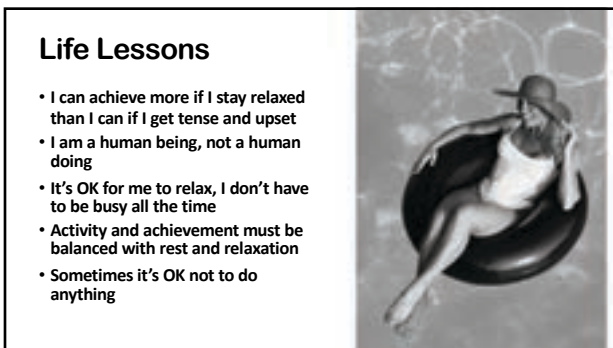

66

Dandelion



- For tension held in the body from driving oneself too hard
- Over-striving in life, trying too hard
- Lack of ability to "go with the flow" of life
- Helps the solar plexus energy, so a person becomes more relaxed and centered
- Also helps a person let go of muscle tension and become more flowing and carefree

67

Willow Flower Essence



- For those who have suffered adversity or misfortune and feel life has been unjust
- They become bitter and resentful
- Their personality becomes "stiff" and they can't move freely through life
- Willow helps a person forgive and let go of the past
- It helps one be flexible in life and embrace life despite hardships and setbacks

68

Radial Furrows

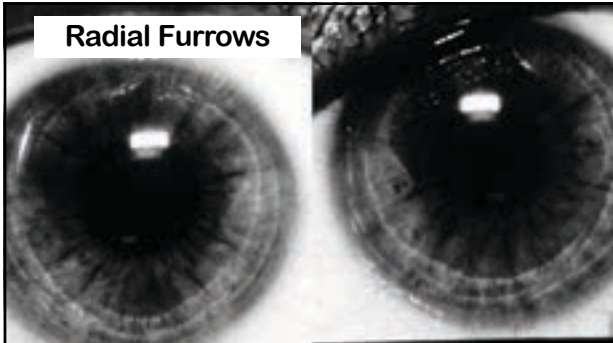

69

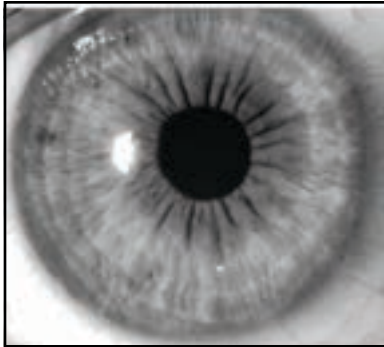

Characteristics

- Tendency to self-defeating, negative mental attitudes; to be overly harsh and critical with self
- Feeling a need to prove one's worth in the world, rather than sensing it inwardly
- May be restless, feel the need to keep striving and doing

70



Pine

- For those who suffer from excessive guilt, self-criticism, self-blame, having an inability to accept themselves
- Aids self-acceptance and self forgiveness
- Helps a person get things off their chest when they feel smothered or stifled
- "I'm not responsible for the abuse I've suffered"
- "I have a right to breathe freely (to be me)"

71

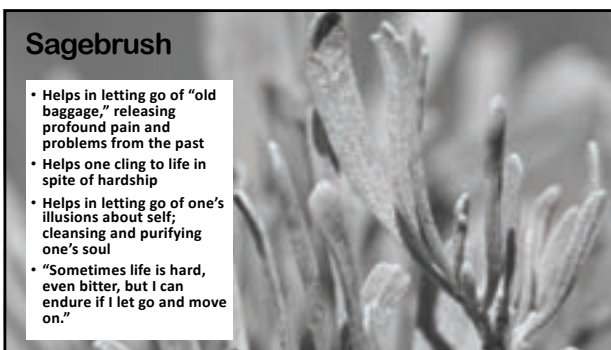

Sagebrush

- Helps in letting go of "old baggage," releasing profound pain and problems from the past
- Helps one cling to life in spite of hardship
- Helps in letting go of one's illusions about self; cleansing and purifying one's soul
- "Sometimes life is hard, even bitter, but I can endure if I let go and move on."

72



73

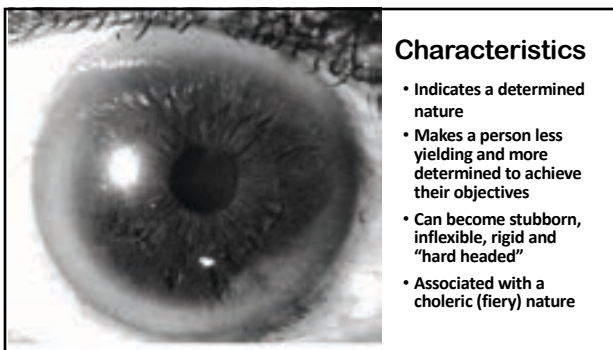

74



75

Rose

- Roses are the primary remedies for opening the heart to experience love and compassion
- They soften the heart, helping a person to let go of sadness, grief, loss and pain
- Rose aids the circulation of blood and allows one to experience greater joy and pleasure in life
- "I can open my heart to the beauty and pleasure of life"



76

Vine (Grape)

- For people who can be domineering and tyrannical, forcing their will on others with little or no consideration for their feelings
- Helps a person lead from a desire to serve, rather than smother others
- "A good leader cares for the feelings of his or her followers"

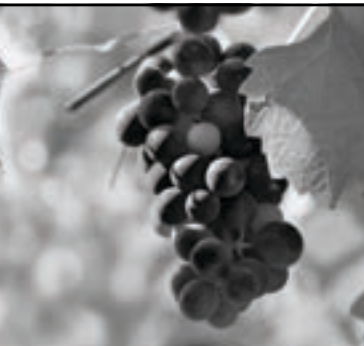

77

Scurf Rim (Ring of Purpose)

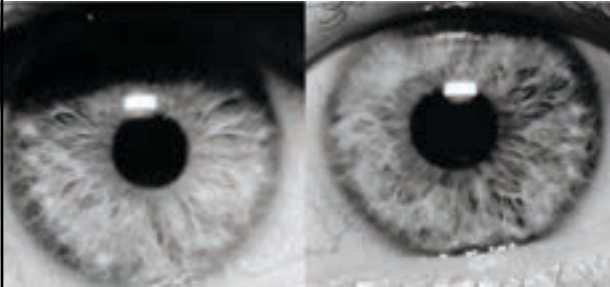

78

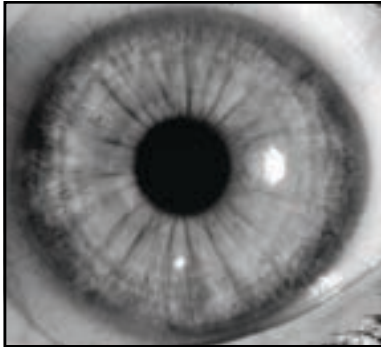

Characteristics

- Has a sense of purpose or destiny, but lacks clarity of what the purpose is and how to express it
- Hiding the true self behind a mask or false front
- Fear of exposure of the inner self
- Unable to bring one's purpose into action in real life

79

Life Lessons

- I am unique and important and God has a purpose for me in my life
- I don't have to understand my full purpose, I can get started in doing something about what is right in front of me
- I can express my genuine self to the world, those who like me will like me, those who don't won't and that's OK



80

Blackberry

- Inability to connect with one's will
- Having lofty goals and dreams but unable to take action to make them come true
- Difficulty organizing thoughts and setting goals
- Helps a person clarify their goals, set priorities and take action to turn their dreams into reality



81

Agrimony

- Hiding behind a mask of cheerfulness
- Unable to acknowledge or express problems or vulnerability, often even to oneself
- Difficulty being genuine with others, always having to "nice"
- "I don't have to put on a 'show' for others"
- It's OK to be genuine, to be who I really am inside"



82

Stomach Zone (Ring of Perfection)



83

Stomach Zone (Ring of Perfection)



- Tendency to be a perfectionist
- "There is a right way and a wrong way to do everything"
- Desire to do things "right"
- Prone to excessive worry and concern over less than perfect performance
- Worry and stress due to being too hard on oneself

84

Life Lessons

- Perfectionism can stand in the way of forward momentum because it prevents people from finishing things
- It can contribute to excessive worry and concern that inhibits constructive action
- There is a point where things are "good enough" and it's time to move forward to the next thing



85

Filaree (Storksbill)

- For people who worry too much about details and small things, tendency to "nit pick"
- Helps a person gain a wider perspective things
- "Don't sweat the small stuff"
- "See the forest as well as the trees"

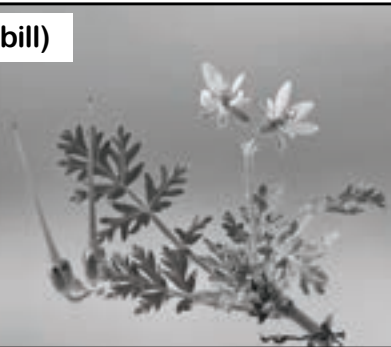

86

Vervain

- Helps people who are passionate idealists, devoted to causes
- Create tension because of their fanatical, driven approach to life
- Can be overbearing and intolerant with others
- May develop nervous exhaustion from pushing themselves too hard
- "I practice moderation, balance, and tolerance"



87

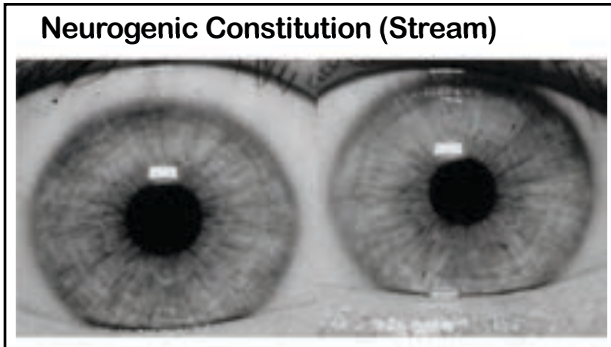

88

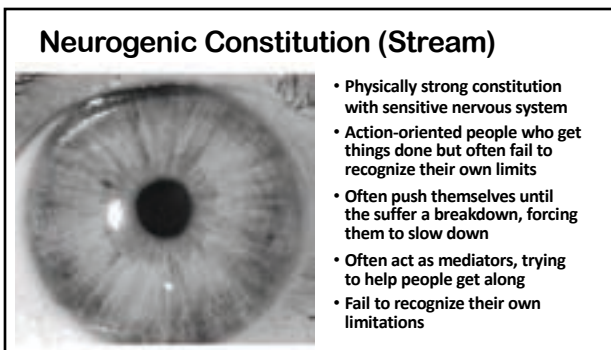

89

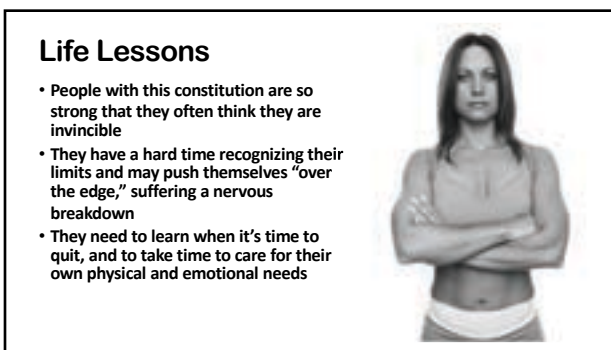

90

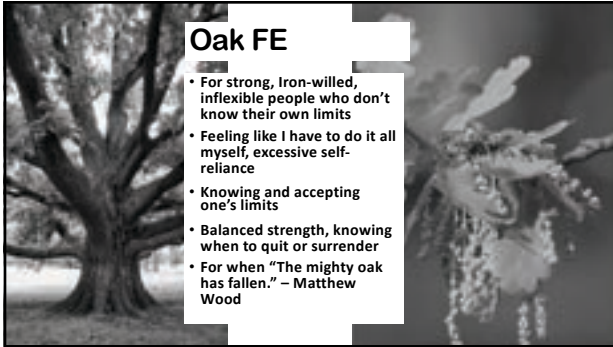

Oak FE

- For strong, iron-willed, inflexible people who don't know their own limits
- Feeling like I have to do it all myself, excessive self-reliance
- Knowing and accepting one's limits
- Balanced strength, knowing when to quit or surrender
- For when "The mighty oak has fallen." – Matthew Wood

91

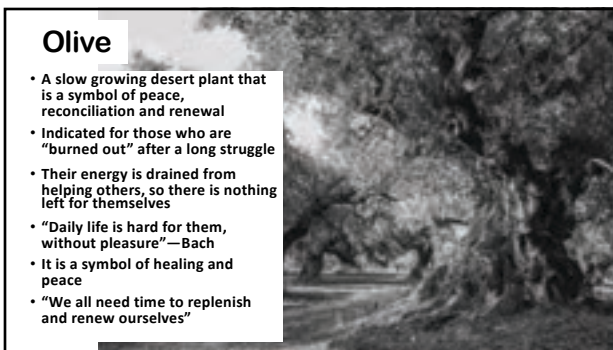

Olive

- A slow growing desert plant that is a symbol of peace, reconciliation and renewal
- Indicated for those who are "burned out" after a long struggle
- Their energy is drained from helping others, so there is nothing left for themselves
- "Daily life is hard for them, without pleasure"—Bach
- It is a symbol of healing and peace
- "We all need time to replenish and renew ourselves"

92

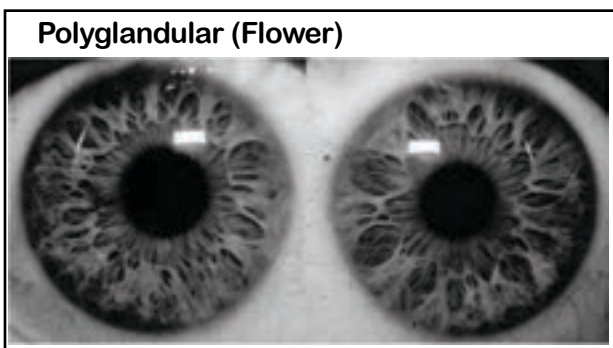

Polyglandular (Flower)

93

Polyglandular (Flower) Characteristics

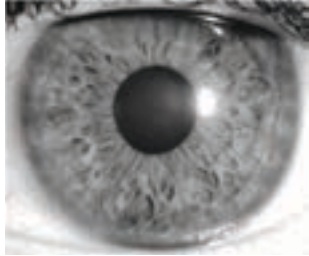

- Flexible, spontaneous, changeable, creative and passionate
- Decisions based on what *feels* right
- Do well in jobs that involve creativity and self-expression
- May be overly dependent on external praise and recognition for self-worth, especially if extroverted
- May feel depressed and empty if unable to be creative
- May have difficulty with follow-through
- Prone to burn-out, lack stamina

94

Life Lessons

- Need to learn to budget and manage energy, avoiding or overcoming "burn out"
- Need to practice commitment and follow-through with ideas and inspiration
- Need to practice self-discipline to take care of their bodies (rest, exercise, good nutrition)
- Need to learn, "It's none of my business what other people think of me."



95

Indian Paintbrush

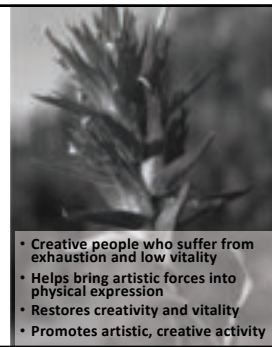

- Creative people who suffer from exhaustion and low vitality
- Helps bring artistic forces into physical expression
- Restores creativity and vitality
- Promotes artistic, creative activity

96

Elm

- For feeling overwhELMed by duties and responsibilities
- Feeling unequal to the tasks at hand
- Helps a person have the faith and confidence to complete tasks and shoulder responsibilities
- "I can bear up under what life has to offer me."

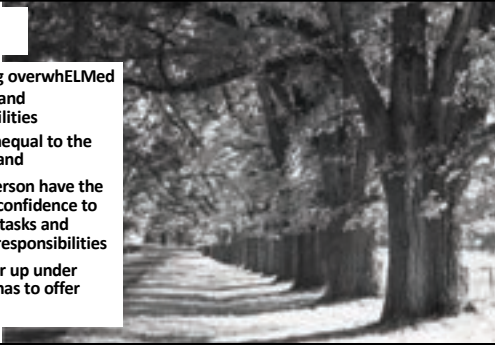

97

Redwood

- Lack of physical strength
- Health issues that deplete vitality
- Problems with bones, spine, and structural system
- Aids physical strength and vitality
- "I can stand tall and strong"



98

To Learn More

- **Subscribe to my newsletter (stevenhorne.com)**
 - Weekly herb article
 - Learn about upcoming classes and publications
- **Purchase my book Strategies for Health**
- **Purchase our charts (simplenatural.net)**
 - Herbal Energetics
 - Aromatherapy for Emotional Healing\
 - Flower Essence chart
- **Join our Member program (stevenhorne.com)**
 - Monthly Sunshine Sharing webinar and newsletter
 - Strategies for Health Consulting course
 - Add a profile to our "Find an Herbalist" page
 - Access to extensive database of products, past webinars, and other tools



99



100
